

The MiniCSU-2 is a control and supervisory unit designed to control up to 225 parallel connected rectifiers (dependent on RT rectifier series), and up to two parallel connected batteries (standard configuration) in a 24VDC or 48VDC uninterruptable power system. It can be expanded to accommodate monitoring functions such as battery cell voltage, AC supply parameter, and site monitoring.

The MiniCSU-2 is well suited to facilitating a network of centrally monitored DC power systems due to its ability to provide remote monitoring and control with WinCSU or WinRPS softwares.



Operating characteristics of the MiniCSU-2 are at 25°C ambient, unless otherwise stated:

Input

Voltage:

54VDC +40/-66% (18VDC – 70VDC)
Suit 24V and 48V systems

Current:

1.5A max at 18VDC;
200mA typical at 54VDC;
(Varies with auxiliary expansion modules)

Protection:

HRC fuse in both input lines. Polarity reversal protection included.

Environmental

Cooling:

Natural convection cooling;

Humidity:

0 to 100% RH condensing

Temperature:

Operating range: -25°C to +70°C

Altitude:

Operational to 4000m.

Compliance standards

EMC:

Designed to ETSI EN 300 386 V1.2.1 (2000)

Safety:

Designed to IEC 60950 (1999)

Environmental:

Designed to ETS 300 019-1-3, class 3.3





Mechanical

Size:

Width:	176mm	(6.93")
Height:	44mm	(1.73")
Depth:	266mm	(10.47")
Mass:	< 1.3kg	(< 2.9 lb)

Magazine size:

The MiniCSU-2 magazine is designed to fit in a 19" (485mm) rack occupying 1U (44mm) of height and accommodates the MiniCSU-2, User Interface Board (MUIB or MUIB2) and optional modem.

Communications

Rectifier Communications Port:

3 wire data connection containing digital transmit and receive lines. All signals optically isolated to > 2kV DC.

Front Panel Mounted RS-232 Port:

9-pin D-connector for direct connection to a PC or Notebook.

Remote monitoring

Optional remote monitoring is available using RS232, RS485, Optical, or LAN/WAN access with a 10BASE-T interface and TCP/IP protocol.

Multiple user access

Two users can be connected at the same time through available communications ports. The later connected user cannot transmit parameters while the first connected user is on line.

Peripherals

System and User Interface:

Interface provided through 34 way ribbon and 16 way auxiliary ribbon cables connected to the magazine back plane. Various configurations of MUIB and auxiliaries are available depending on system requirements: (see below)

MUIB:

Provides connection to the following system peripherals/monitoring points:

- System/Battery voltage
- 2 battery current transducers
- Ambient and battery temperature sensors
- Load and Battery Circuit breaker trip input (digital)
- Low Voltage Disconnect Switch (LVDS) control
- LVDS auxiliary contact input (digital)
- 4 alarm relays (Fan speed, HVSD, Alarm, SMR shutdown)
- 4 spare digital input lines for monitoring plant (special software required)
- 2 spare analog inputs
- 1 user defined control relay (special software required)

MUIB2:

Basic functionality of MUIB with additional features:

- 4 battery current transducers
- 1 load current transducer
- 16 way auxiliary ribbon connected in a "daisy-chain" through MUIB2 to enable Battery Cell, Site and 3 ϕ mains monitoring simultaneously.

3 phase AC monitor (MMIB2)

Connected through auxiliary port, monitors voltage and current of each phase. Frequency monitored on two phases only.

Battery Cell Monitor (BCM):

Connection to MiniCSU-2 is made via the 16 way auxiliary ribbon cable. Individual wires to each cell of battery strings provide cell voltage information. Up to 4 BCMs, each monitoring 24 cells, can be connected.

Site Monitor Module (SMM):

Connection to MiniCSU-2 is made via the 16 way auxiliary ribbon cable. Input and output controls are defined using WinCSU software on a PC. The site monitor provides:

- 8 user defined analog inputs
- 12 user defined digital inputs
- 4 relay control outputs





Front Panel

Push Buttons:

Six push-buttons are available on the front panel. Three push-buttons are used to move through the various menus and for making alterations to operating parameters. Three other push-buttons enable entry into three additional menus:

- INC - increases parameter value or moves forward through a menu,
- DEC - decreases parameter value or moves backward through a menu,
- ENTER - accept new value or open sub-menu,
- SMR - opens SMR parameter menu,
- BATT - opens battery parameter menu,
- LOG - opens Alarm Log menu.

Alphanumeric Display:

Two line, 16 character, vacuum fluorescent display (VFD). Normally displays output voltage and current as well as the system status - Float or Equalise.

Status LEDs:

Three LEDs to the right of the push buttons are used to indicate system status:

- GREEN - System operating normally
- YELLOW (Flashing) - System alarm
- YELLOW (Constant) - Equalise operation mode
- RED - SMR Off or faulty

Alarms

Alarms are displayed on the MiniCSU-2 front panel as an alarm menu that activates only when an alarm is registered. An audible alarm can also be enabled to alert personnel. Individual alarms are displayed by INC or DEC through alarm menu.

All alarms are displayed simultaneously in the Alarm Window of WinCSU.

Adjustable System Alarms:

Alarm	Range	Steps
<i>24V Systems</i>		
Voltage high alarm	26.0-33.0V	0.1V
Voltage low alarm	20.0-27.0V	0.1V
Battery discharge alarm	22.0-26.0V	0.1V
<i>48V Systems</i>		
Voltage high alarm	52.0-66.0V	0.1V
Voltage low alarm	40.0-54.0V	0.1V
Battery discharge alarm	44.0-52.0V	0.1V
<i>All Systems</i>		
Ambient temperature high alarm	30-90°C	1°C
Battery temperature high alarm	30-90°C	1°C
Differential battery discharge current	5-99A	1A

Non-adjustable System Alarms:

Alarm	Source	State
Power Distribution Unit Fuse Fail	Voltage-free contacts	Open
Battery Switch Open	Voltage-free contacts	Open
LVDS Open <i>Auxiliary contacts of contactor</i>	Voltage-free contacts	Open
EEPROM Fail <i>Default values replace bad data</i>	Software	-
Battery Temp. Sensor Fail	Software	-
System Voltage Clamp <i>Excessive voltage drop along bus bar</i>	Software	-

Processor Fail <i>Indicated by front panel red LED only</i>	Internal circuit	-
--	------------------	---

Adjustable SMR Alarms:

Alarm	Range	Steps
<i>24V Systems</i>		
SMR voltage high alarm	26.0-32.5V	0.1V
SMR voltage low alarm	22.0-27.0V	0.1V
SMR HVSD	27.0-33.0V	0.1V
<i>48V Systems</i>		
SMR voltage high alarm	52.0-65.0V	0.1V
SMR voltage low alarm	44.0-54.0V	0.1V
SMR HVSD	54.0-66.0V	0.1V

AC Supply Monitoring Alarms:

Available when optional module is used.

Alarm	Range	Steps
AC supply high voltage alarm	220-315V	1V
AC supply low voltage alarm	140-270V	1V
Frequency high alarm	50.0-65Hz	0.1Hz
Frequency low alarm	40.0-60Hz	0.1Hz

Battery Cell Monitoring Alarms:

Available when optional module is used. Batteries built of different types of cells can be used. 4V, 6V or 12V monoblocks can be monitored as well as single 2V cells

Alarm	Range	Steps
Cell Low Voltage Alarm	1.0-12.0V	0.01V
Cell High Voltage Alarm	2.0-16.0V	0.01V
Cell Positive Deviation Alarm	5-99%	1%
Cell Negative Deviation Alarm	5-99%	1%



Monitoring and Control

SMR Status:

MiniCSU-2 and WinCSU monitor status of the SMR:

- Output current of SMR;
- Temperature of heatsink of SMR;
- Software version of SMR;

Load/Battery Current:

Monitored on MiniCSU-2 and WinCSU with 0.1A or 1A resolution dependent on system size; Analog measurement accuracy $\pm 1\%$ at full load;

System Voltage:

System voltage displayed on front panel alphanumeric display. Remote monitoring using WinCSU. Analog measurement accuracy $\pm 0.5\%$

Remote Reporting:

The software has automatic reporting features whereby a PC running WinCSU software is

contacted via a modem, RS485 line, Optical link, or RS232 connection in the event of an alarm condition occurring, or at regular daily time. For modem dial-up:

- Up to 3 phone numbers are dialled sequentially until connection made
- Up to 20 digits in each phone number

Network Connection:

Network connection via optional 10BASET interface using TCP/IP protocol is available and optional WinRPS software polls up to 512 MiniCSU-2 controllers on the network.

Digital active current sharing

Normal system operation is made with continuous active current sharing of SMR currents. Accuracy of sharing typically 2% of rated SMR current (limited by SMR tolerances).

Programmable Parameters

Rectifier Operating Parameters:

SMR operating parameters programmable from the MiniCSU-2: (values written to all SMRs in system)

- Float and Equalise voltage levels.
- Current limit (in 1A steps) dependent on type of SMR.
- Passive current sharing adjustment (done automatically when: MiniCSU-2 is powered-up, or a rectifier in the system has been replaced, or at the end of an equalisation cycle)

Actual programmed output voltage from SMR is the sum of the Float/Equalise voltage, system voltage drop (user adjustable) and the battery temperature compensation voltage (if active).

Battery Equalisation Parameters:

Automatic equalisation of the battery with selectable start and end parameters;

Parameter	Range	Steps
<i>24V Systems</i>		
Equalise start voltage	22.0-25.0V	0.1V
Equalise voltage	25.0-30.5V	0.1V
<i>48V Systems</i>		
Equalise start voltage	44.0-50.0V	0.1V

Equalise voltage	50.0-61.0V	0.1V
<i>All Systems</i>		
Equalise start discharge AH	5-99AH	1AH
Equalise time duration	3-48 Hrs	1 Hr
Equalise end battery current	**	1A
Periodic equalise interval	1-52 weeks	1 week

** Current range limits are based on user defined parameters:
 =(10% of BatLim3 OR 3% of Sensor FSD) - 20% of Bat. AH
 Note: On units with software version Gxxxx fc and higher,
 equalisation can be disabled

Battery Charging Parameters:

Parameter	Range	Steps
<i>24V Systems</i>		
Deep discharge range limit (Vdd)	20.0-24.0V	0.1V
Float charge range limit (Vfl)	24.0-29.0V	0.1V
<i>48V Systems</i>		
Deep discharge range limit (Vdd)	40.0-47.0V	0.1V
Float charge range limit (Vfl)	48.0-58.0V	0.1V
<i>All Systems</i>		
Battery current limit range below Vdd	5-999A	1A
Battery current limit between Vdd & Vfl	5-999A	1A
Battery current limit above Vfl	5-999A	1A
Battery (V) temp. compensation (BTC)	0-6mV/°C/cell	0.1mV
Zero BTC voltage set point temp.	18°C-27°C	1°C
BTC operating range	10°C-35°C	-



MiniCSU-2 Controller

Specification

LVDS Parameters:

Parameter	Range	Steps
<i>24V Systems</i>		
Trip level range	20.0-23.5V	0.1V
<i>48V Systems</i>		
Trip level range	40.0-47.0V	0.1V
<i>All Systems</i>		
Reconnect level	Vfloat - 1V	-

Other System Parameters:

Parameter	Range	Steps
Batt. current transducer full scale current	10 - 9990A	10A
Load current transducer full scale current	50 - 9990A	10A
Batt. current transducer full scale voltage	±4V	-
Load current transducer full scale voltage	+4V	-
Number of Batteries (using MUIB2)	1-2 (4)	1
Load current transducer (activation)	ON/OFF	-
Battery capacity	20-9999AH	1AH

Battery Discharge Test:

Battery Discharge Test performs a periodic, controlled battery discharge using the normal system load to discharge the battery. The test can be used to confirm capacity of the battery and is disabled for 100 hours if:

- AC failure has been recorded
- Electrolyte low level has been recorded (only on systems using sensor and special software)
-

Parameter	Range	Steps
BDT Period (Days)	Off, 1 - 365	1 day
BDT Time (24 Hour Format)	00:00-23:59	1 min
BDT Duration (Hours:Minutes)	0:05-24:00	5 min
BDT Current	0 – 5000A	1A
BDT End Capacity (Q)	25–9995AH	5AH
<i>24V Systems</i>		
BDT End Voltage	18 – 24V	0.1V
<i>48V Systems</i>		
BDT End Voltage	36 – 48V	0.1V

Other features

- Operating parameters of the system are stored in nonvolatile memory located on the magazine back plane so no programming of a replacement unit is required.
- 100 event alarm log also stored in nonvolatile memory on the magazine back plane.
- The software can be upgraded through any communications port without disturbing system operation.
- Password protection against unauthorised parameters change.
- Test mode allowing system test without permanent altering of system parameters and alarm log content.

MiniCSU-2 Dimensions:

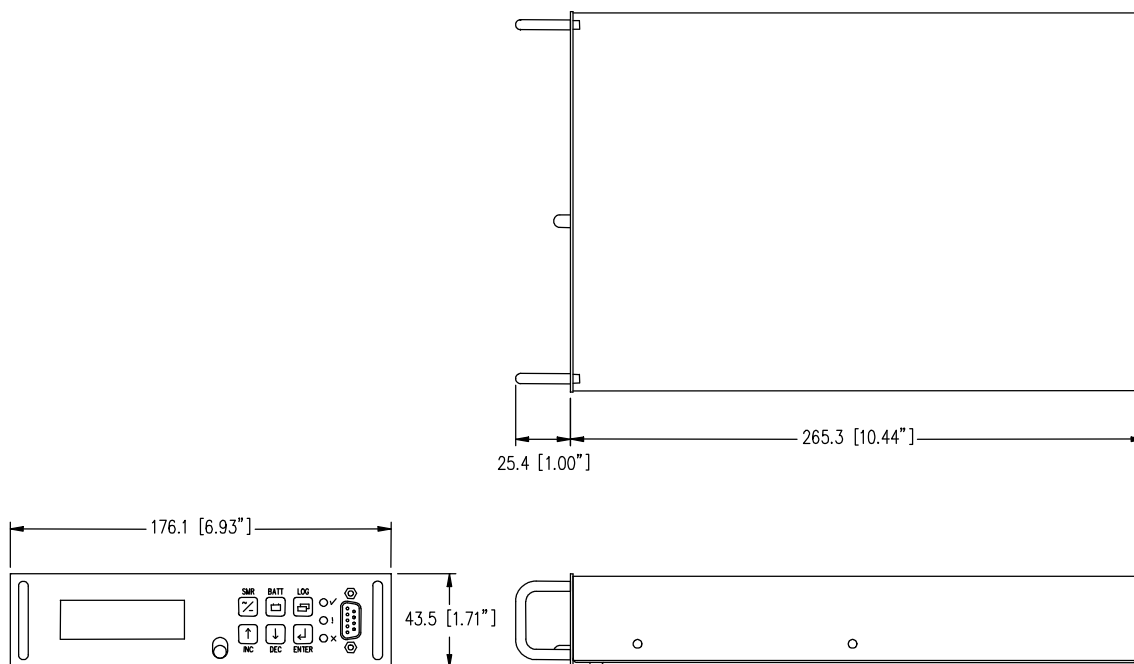



MiniCSU-2 Magazine Dimensions:

